



# ASTRA 4000RS SERIES

**VEHICLE SECURITY SYSTEM  
WITH REMOTE START**

*WITH SEPERATE LOCK/UNLOCK BUTTONS*

**PRODUCT MANUAL**

## Limited Lifetime Warranty

This vehicle security system is warranted to the original purchaser, to be free from defects in material and workmanship. The manufacturer will repair or replace at its option, and free of charge for the first twelve (12) months, any part that proves defective in material or workmanship under normal installation, use, and service, provided the product is returned to the manufacturer freight prepaid. After the first 12 month warranty period there will be a maximum service charge of \$25.00 per calendar year (if required) for repair and/or replacement of any defective parts.

**A copy of the original purchase and installation receipt must accompany any products returned for warranty service.** Warranty is limited to defective parts and/or replacement parts only and excludes any incidental, and consequential damages connected therewith.

The manufacturer of this theft deterrent system makes no warranty against the theft of the vehicle or its contents. This warranty is not to be construed as an insurance policy against loss.

WARRANTY OF INSTALLATION LABOR, REMOVAL AND RE-INSTALLATION CHARGES ARE NOT THE RESPONSIBILITY OF THE MANUFACTURER.

**Note: This Warranty is voided if the product was not installed by an Authorized ScyTek Dealer.**

# Table of Contents

1.	About Your System	Page 1
2.	Remote Transmitters	Page 2
	Remote Transmitter Description	Page 2
	Adding/Replacing Transmitters	Page 3
	Two Car Operation	Page 3
	Battery Replacement	Page 3
	Optional 2-way LCD Remote Transmitter Description	Page 4-7
	Adding/Replacing Optional 2-way Transmitters	Page 4
	LCD Transmitter Battery Replacement	Page 5
3.	System Operation	Page 8
	Remote Arming	Page 8
	Remote Disarming	Page 8
	Tamper Alert	Page 9
	Silent Arming/Disarming	Page 9
	Passive Arming	Page 9
	Panic Mode	Page 10
	Emergency Override	Page 10
	Optional Coded Emergency Override	Page 10
	Automatic Rearming	Page 11
	Valet Mode	Page 11
	Driver calling/Page Feature	Page 11
4.	Remote Start Feature	Page 12
	Remote Starting	Page 12
	Shut Down	Page 12
	Quick Stop	Page 12
	Automatic Start Mode	Page 13
5.	Extended Features	Page 14
	Ignition Door Locking	Page 14
	Ignition Door Unlocking	Page 14
	Dome Light Activation	Page 14
	Auxiliary Function Outputs	Page 14
	Disarm with Auxiliary Function	Page 14
	Remote Sensor Disable	Page 14
6.	System Installation	Page 15
	Mounting the Control unit	Page 16
	Mounting the Siren	Page 16
	Mounting the Shock Sensor	Page 16
7.	System Wiring	Page 17
	6-Pin Starter Harness	Page 17
	16 -Pin Main Harness	Page 17
	Plug-in Connectors	Page 18
8.	Jumper Settings	Page 19
	Jumper Selection	Page 19
9.	System Programming	Page 20
	Entering System Programming	Page 20
	Default Reset	Page 20
	Programmable System Options	Page 20
	Branch Table	Page 21
10.	Relay Diagrams	Page 23
11.	Door Lock Diagrams	Page 24
12.	Two Stage Door Lock Diagrams	Page 25
13.	Technical Information	Page 27
14.	System Diagnostics	Page 27
15.	Wiring Diagram	Back Page

# About Your System

The ScyTek Astra 4000RS SERIES is a combination vehicle security and remote starting system. With proper installation this system will provide superior protection and performance for many years to come.

The Astra 4000RS SERIES built-in remote start feature is designed to offer maximum convenience by remote starting your vehicle's engine, turning on the heater/air conditioner, and then running for a pre-determined time to provide a comfortable environment once you enter your vehicle.

To ensure the safety and security of the system while it is remote started, the Astra 4000RS SERIES employs several safeguards. In the event the alarm is triggered while the engine is remotely running, the remote start will immediately shutdown to prevent unauthorized users from attempting to drive the vehicle. The system is equipped with a hood pin input to prevent access to the engine compartment while the vehicle is remotely running. The Valet Mode prevents the remote start feature from operating in the event the vehicle is to be serviced. Finally, the brake pedal also acts as a safety by shutting down the remote start when pressed.

## System Contents:

- Main Unit
- One 5-Button 2-Way LCD Remote and One 5- Button Random Code Transmitter (4000RS-2W-1)
- Two 5-Button Random Code Remote Transmitters (4000RS)
- High Output 6-tone Siren
- Dual Stage Shock Sensor
- Status LED
- Coded Emergency Override / Valet Switch/Call Button Built into the Antenna. (see page 27)

## Options and Convenience Features\*

This ScyTek system includes several optional inputs and outputs allowing the creation of a completely personalized security and convenience system by offering many optional features such as:

**\*May require additional parts and/or labor, see store for details.**

- Second Car Operation
- Keyless Entry
- Two Stage Door Unlocking
- Starter Defeat
- Horn Honk
- Illuminated Entry
- Channel Expansion Module
- Remote Window Control
- Power Trunk / Hatch Release
- Glass Breakage Sensor
- Radar Sensor
- Remote Head Lamp Control
- Back-up Battery Siren

### PLEASE NOTE:

Some of the features described in this manual may require additional parts and/or labor, and may not be included as part of the standard installation of this unit. Additionally, many features of this security system have selectable options that must be activated or programmed during the system's installation. These items will be identified in the following sections. Please discuss these features and any questions you may have regarding the installation of this product with Your Authorized Dealer.

# Remote Transmitters

## ***Standard Remote Transmitter Description***

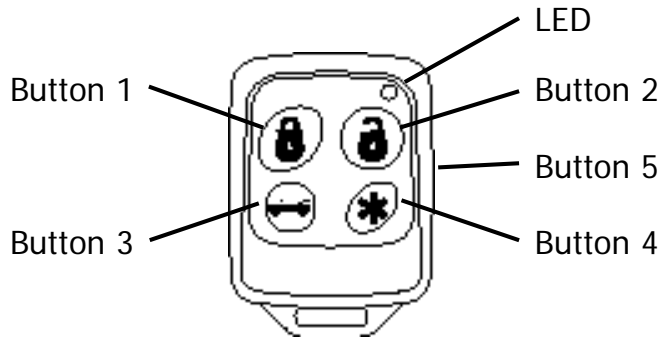

The Astra 4000RS Series comes equipped with the 5-button Remote Transmitters used to control system operations.

*Button 1* Arms the system and when held for 5 seconds, activates the system's Panic feature. Button 1 also locks the doors when the system is in Valet Mode.

*Button 2* Disarms the system. Pressing Button 2 again operates the Passenger Unlock feature (if installed). Button 2 also unlocks the doors when the system is in Valet Mode.

*Button 3* Activates the Auxiliary 1 output. This output will remain on for as long as the button is pressed.

*Button 4* Activates the Remote Start feature.

*Button 5* is the Page Shift button. Each time the Shift Button is pressed, the LED on the transmitter will illuminate and the transmitter functions will shift to the next page, allowing access to another set of features. Once shifted to another page (there are 4 pages total), the transmitter will remain on that page for 10 seconds or until a button is pressed, then return to page 1. Each time a transmitter button is pressed and held, the LED will flash a number of times to indicate from which page it is transmitting. Under normal operation, only pages 1 and 2 are used. Pages 3 and 4 are usually used for Two Car Operation (see page 3) or optional channel expansion modules.

*Shift then Button 1* Arms the system silently.

*Shift then Button 2* Disarms the system silently.

## ***Adding/Replacing Transmitters***

To replace lost or stolen transmitters or to add additional transmitters into the system, have all desired transmitters ready and follow the steps below.

**Note:** Up to 4 one-way transmitters can be programmed to operate the system. Any previously stored transmitter codes will be erased if they are not programmed within the following sequence.

To program the transmitter(s):

1. Turn on the ignition key On, Off, On, Off, and back On. (Key On 3 times)
  - The siren will chirp 3 times.
2. Press and hold the Override switch for 5 seconds.
  - The siren will chirp 5 times.
  - The LED will illuminate.
3. Press Button 1 on the first transmitter.
  - The siren will chirp once.
4. Press Button 1 on the first transmitter again.
  - The siren will chirp twice to indicate it has learned the code.
5. Repeat steps 3 and 4 for each transmitter (up to 4).
6. Turn off the ignition key.

## ***Two Car Operation***

If two vehicles are equipped with Astra 4000RS Series system, for convenience both can be operated using the same remote transmitter. If all four transmitters are to be used with both cars, program transmitters A and B into the first vehicle in the manner described above. Program transmitters C and D by pressing the Shift button twice before performing steps 3 and 4 above.

When finished programming the first vehicle, program transmitters C and D into the second vehicle as normal, then program transmitters A and B by pressing the Shift button twice before performing steps 3 and 4 above.

When programmed in this manner, the driver of the first car can also operate the second vehicle by pressing the Shift button twice and the desired function button.

## ***Battery Replacement***

Your Astra Remote Transmitter uses a 12 volt alkaline battery (type 23A), which will require replacement in time. Depending on the amount of use, the battery may last up to six months or more before it needs replacement. When the battery needs replacing, the system's operating range will decrease or the transmitter LED may not be as bright.

In order to change the battery, first remove 2 screws from the back of the transmitter and separate the top and bottom halves of the case. While replacing the battery make sure that the positive and negative terminals are positioned correctly, then carefully reassemble the transmitter case.

## **2-way LCD Remote Transmitter Description**

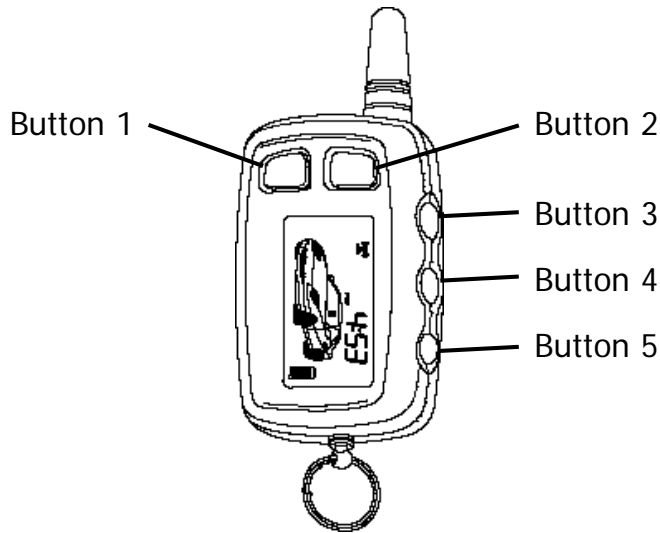

The Astra 4000RS-2W-1 is supplied one 2-way LCD remote transmitter, offering increased range and confirmation of any activated features.

*Button 1* Arms the system and when held for 5 seconds, activates the system's Panic feature. Button 1 also locks the doors when the system is in Valet Mode.

*Button 2* Disarms the system. Button 2 also unlocks the doors when the system is in Valet Mode.

*Button 3* Activates the Auxiliary 1 output normally used for trunk release (note trunk icon on button).

*Button 4* Activates the Remote Start feature.

*Button 5* is the Confirmation, Programming and the Page Shift button. Quickly pressing button 5 will activate the Page 2 function. Pressing button 5 for 2 seconds activates the system's confirmation feature which will then display the current status of the system (*armed, disarmed, engine running, etc.*).

### **Page 2**

*Button 1* Silently Arms the system.

*Button 2* Silently Disarms the system.

## **Adding/Replacing Optional 2-way LCD Transmitters**

When adding a 2-way LCD transmitter to the system, follow these steps:

1. Turn on the ignition key On, Off, On, Off, On, Off, and back On. (Key On 4 times)
  - The siren will chirp 4 times.
2. Press and hold the Override switch for 5 seconds.
  - The siren will chirp 4 times.
  - The LED will illuminate.
3. Press Button 1 on the first transmitter then on the second transmitter.
  - The siren will chirp once for each transmitter learned.
4. Turn off the ignition key.
5. The siren will chirp three times to indicate system has exited programming mode.

## ***LCD Transmitter Battery Replacement***

Your Astra Remote Transmitter uses a 1.5 volt AAA alkaline battery, which will require replacement in time. Depending on the amount of use, the battery may last up to three months before it needs replacement. When the battery needs replacing, the system's operating range will decrease, the LCD display will show only one of three bars in the battery icon, or the display and sounds may suddenly stop and start as the battery voltage drops below minimum.

In order to change the battery, first slide the battery door locking pin to the side. Carefully slide the battery cover downward until it is free. While replacing the battery make sure that the positive and negative terminals are positioned correctly, then carefully reassemble the transmitter case.

## ***Setting The Time***

The LCD display is equipped with a 12-hour clock that in addition to displaying the time, offers an alarm clock function as well as a remote activation timer.

To set the time:

1. Press and hold Buttons 2 and 3 for three seconds.
  - The remote will beep two times and three bars will be shown indicating time set mode is entered.
2. Press Button 2 until the correct hour is displayed.
3. Press Button 3 until the desired minute is displayed. The button may be held down to scroll faster.
4. When the desired time is displayed, press Button 5 to store.
  - The remote will play a melody to indicate the time has been set.

## ***Setting The Alarm Clock***

The alarm clock function can be set to play an alert melody at a specific time of day.

To set the alarm clock function:

1. Press and hold Buttons 2 and 3 until the remote beeps three times.
  - The alarm clock bell and three bars will be shown indicating alarm clock set mode is entered.
2. Press Button 2 until the desired hour is displayed.
3. Press Button 3 until the desired minute is displayed. The button may be held down to scroll faster.
4. When the desired time is displayed, press Button 5 to store.
  - The remote will play a melody to indicate the alarm clock has been set.

To disable the alarm clock function:

1. Press and hold Buttons 2 and 3 until the remote beeps three times.
  - The alarm clock bell and three bars will be shown indicating alarm clock set mode is entered.
2. Press Button 1 to disable the alarm clock.
  - The remote will play a melody to indicate the alarm clock has been disabled.

## ***Setting The Automatic Start Or Auto Activate Function***

The Automatic Start Function provides a timer that allows the vehicle to automatically remote start at a preset time of day. For non-remote start equipped systems, this feature allows activation of an auxiliary feature at a preset time of day.

To set the automatic start / auto activate function:

1. Press and hold Buttons 2 and 3 until the remote beeps four times.
  - The fan and clock will be shown indicating automatic start mode is entered.
2. Press Button 2 until the desired hour is displayed.



4. When the desired time is displayed, press Button 5 to store.
  - The remote will play a melody to indicate the alarm clock has been set.

To disable the automatic start / auto activate function:

1. Press and hold Buttons 2 and 3 until the remote beeps four times.
  - The fan and clock will be shown indicating automatic start mode is entered.
2. Press Button 1 to disable the alarm clock.
  - The remote will play a melody to indicate the alarm clock has been disabled.

### ***LCD Backlight***

Transmitter Button 5 is used for confirmation, transmitter programming, as well as activation of the LCD backlighting for use in the dark. Press button 5 to activate the LCD backlight.

### ***System Confirmation***

The 2-way transmitter's confirmation feature allows the current vehicle status to be displayed at any time.

To display system status:

1. Press and hold Button 5 until the display shows CON.
  - The transmitter will beep once.
2. Release Button 5.
  - The transmitter will beep once.
  - The icons representing current system status will be displayed on the LCD panel.

### ***Transmitter Programming***

Pressing and holding transmitter button 5 will scroll through several transmitter programmable options that may or may not be available depending on the model of system installed- CHP, DEG, SND, and PSV. The CHP or chirp function allows remote enabling or disabling of the vehicle siren's confirmation chirps.

Note: This feature may not be available on all systems.

To turn the siren chirps on or off:

1. Press and hold Button 5 until the display shows CHP.
  - The transmitter will beep twice.
2. Release Button 5.
  - The transmitter will beep once.
  - The LCD panel will show a siren if the chirps are enabled or "off" if the chirps are disabled.

DEG or degrees (not used)

The SND or sound function allows disabling of the transmitter's confirmation tones.

To turn the transmitter confirmation tones on or off:

1. Press and hold Button 5 until the display shows SND.
  - The transmitter will beep three times.
2. Release Button 5.
  - The transmitter will beep once.
  - The LCD panel will play a tone if the sounds are enabled or "off" will be displayed if the chirps are disabled.

The PSV or passive function allows the passive arming mode to be enabled or with the transmitter.

Note: This feature may not be available on all systems.

To enable or disable the passive arming mode:

1. Press and hold Button 5 until the display shows PSV.
  - The transmitter will beep four times.
2. Release Button 5.
  - The transmitter will beep once.
  - The LCD panel will play a tone if the sounds are enabled or "off" will be displayed if the chirps are disabled.



**System Armed** indicates the doors are locked and the alarm is on.



**System Disarmed** indicates the doors are unlocked and the alarm is off.



**Engine Run** indicates the engine is running on remote start equipped systems



**Trunk Release** indicates the trunk or auxiliary function has been activated.



**Door Open** indicates the door zone has been triggered.



**Shock Sensor** indicates the shock sensor has been triggered.



**Warn Away** indicates the warn away has been triggered.



**Trunk Open** indicates the trunk or hood zone has been triggered.



**Alarm Clock** indicates the programmable timer function has been set.



**Valet Mode** indicates the system has been placed into valet mode.



**Battery Low** indicates the battery inside the transmitter needs to be replaced.



**Panic** indicates the panic mode has been triggered.



**Auto Run** indicates the automatic remote start timer has been set.

# System Operation

## **Remote Arming**

The system monitors 5 independent areas (**zones**) while armed: doors, hood, trunk, shock sensor, optional sensor input, and the network port for future expansion.

To Arm the System:

1. Turn off the ignition.
2. Press Button 1.
  - The siren will chirp once.\*
  - The doors will lock.
  - The parking lights will flash once.
  - The LED will turn on red, to indicate the starter defeat is activate.
3. 10 seconds after Arming:
  - The LED will start blinking to indicate that the doors, hood, trunk and sensor inputs are being monitored.

\* **During Arming, if the system detects a bad sensor or an open zone, the system will chirp 4 additional times and ignore that input, but keep all other areas protected.**

Once Armed, the alarm will trigger when any of the following occurs:

- **The doors are opened.**
- **The hood or trunk is opened.**
- **The shock sensor detects an impact to the vehicle.**
- **An optional sensor is disturbed.**

When the alarm triggers, the siren will sound, the horn will honk, and the parking lights will flash. If the system is triggered by the doors, hood, or trunk, the system will alarm for 45 seconds. If triggered by the sensor inputs, the system will alarm for 30 seconds.

In the event the alarm is triggered and remains triggered continuously by the same sensor or input during a single arming cycle, that sensor or input will be automatically bypassed until the next time the system is armed.

If the Shock Sensor detects a light impact to the vehicle the siren will chirp 5 times as a warning indication.

## **Remote Disarming**

To Disarm the System:

Press Button 2.

- The siren will chirp twice.\*
- The doors will unlock.
- The parking lights will flash twice.
- The dome light will turn on.\*\*
- The LED will turn off.

\* **During Disarming, if the system was triggered while away from the vehicle, the siren will chirp 3 times, the parking lights will flash 3 times, and the LED will flash to indicate triggered zone. See *Tamper Alert* for zone listing.**

\*\* **If the optional Dome Activation Feature was installed.**

## ***Tamper Alert***

If the system was triggered while away, the LED will flash to indicate which zone triggered the system after disarming and turning on the ignition. The LED indication will repeat 8 times.

LED Flashes (60 seconds):

<b>1 flash</b>	<b>=</b>	<b>optional sensor</b>
<b>2 flashes</b>	<b>=</b>	<b>shock sensor</b>
<b>3 flashes</b>	<b>=</b>	<b>network based sensor</b>
<b>4 flashes</b>	<b>=</b>	<b>door</b>
<b>6 flashes</b>	<b>=</b>	<b>trunk</b>

example: flash-flash-pause-flash-flash-pause = shock sensor

## ***Silent Arming/Disarming***

The Astra 4000RS Series system can be programmed to operate the system without Arm and Disarm chirp indications. When programmed for full-time silent operation, the siren will sound only when the system is triggered.

The system is also capable of temporary silent operation if desired. Pressing the Shift button before Arming or Disarming the system will bypass the chirp confirmations and allow one-time silent operation.

**Note:** The open zone warning chirps will not be bypassed when the system is Armed or Disarmed silently.

## ***Passive Arming***

When programmed for the optional Passive Arming feature, the system arms itself automatically, each time the ignition is turned off and all of the doors, hood, and trunk are closed.

To start the Passive Arming Process:

1. Turn off the ignition.
2. Open the door and exit the vehicle.
  - Once all doors are closed and the dome light is off, the LED will begin flashing rapidly.
  - The parking lights will flash twice indicating the Passive Arming sequence has begun.
3. After 30 seconds,
  - The siren will chirp.
  - The parking lights will flash.
  - The doors will lock.\*
  - The status LED will begin flashing.
4. The system is now armed.

\* If the Passive Locking feature is selected.

## ***Panic Mode***

In the event of an emergency the transmitter's remote Panic feature can be used to instantly trigger the alarm.

To activate the Panic Mode:

1. Press and hold Button 1 for five seconds.
  - The alarm will sound.
  - The parking lights will flash.
  - The doors will unlock\* allowing access to the vehicle.
2. Press Button 2 to stop Panic Mode.

\* **If the ignition is on when the Panic feature is activated, the doors will lock for personal safety.**

If not deactivated using Button 2, the Panic Mode will automatically exit after 30 seconds and the system will be restored to its previous Armed/Disarmed state.

## ***Emergency Override***

If the transmitter becomes lost or inoperable, the system can still be disarmed using the following procedure. Before beginning this procedure be sure to have the ignition key ready and know the location of the override switch.

To Emergency Override the system:

1. Unlock the door using the key.
2. Enter the vehicle.
  - The system will trigger and the siren will sound.
3. Turn ignition key on.
4. Press and hold the override switch until the alarm shuts off.
  - The system will disarm.
5. The vehicle will now be able to start.

## ***Optional Coded Emergency Override***

As an extra measure of security, the Astra 4000RS Series is equipped with an optional Coded Emergency Override feature. Once an Emergency Override Code is chosen and programmed during installation, the system can no longer be disarmed using the standard override procedure.

To Emergency Override the system using the Code:

1. Follow steps 1-3 above.
2. Press the override switch a number of times equal to the Disarm code, and continue holding for 10 seconds on the last press.
  - The system will disarm. If the code is entered incorrectly, turn off the ignition and begin again.

To set the Emergency Override Code:

1. Turn on ignition.
2. Within 5 seconds, press the valet switch 5 times.
  - The siren will provide one long chirp, indicating that you have entered Programming.
3. Press the valet switch 6 times.
  - The siren will chirp each time the valet switch is pressed.
4. Within 5 seconds, press Button 3 on the transmitter.
  - The siren will chirp 3 times.
5. Press the valet switch the number of times equal to the desired code (from 1-15).
6. Turn off the ignition then arm the system.
7. Disarm the system using the new Override Code to permanently store the new code.

**Note:** If the code set procedure is not properly performed, turn off the ignition and begin again. The override code will not be permanently stored until the code is used to disarm the system.

### ***Automatic Rearming***

The Automatic Rearming feature is designed to protect the vehicle in the event the system is accidentally disarmed. With the Automatic Rearming feature enabled, the alarm will automatically rearm and lock 30 seconds after disarming.

The Automatic Rearming feature functions separately from the Passive Arming feature. The Automatic Rearming feature will be temporarily bypassed until the next arming cycle if the ignition is turned On.

### ***Valet Mode***

The Valet Mode temporarily disables the security and remote start system so the vehicle may be operated by a mechanic or parking attendant.

To activate or deactivate the Valet Mode:

1. Turn on the ignition.
2. Press and hold the override switch for 5 seconds.
  - The siren will chirp once and the LED light will stay ON to confirm the Valet Mode is on.
  - The siren will chirp twice and the LED light will turn OFF to confirm the Valet Mode is off.
3. Turn off the ignition.

While in Valet Mode the remote transmitters will continue to lock and unlock the doors, and operate the optional auxiliary functions.

### ***DRIVER CALLING/PAGE FEATURE***

The Astra 4000RS Series is equipped with a driver calling or paging feature that allows the system to send a page to the LCD transmitter in the event the transmitter has been misplaced or lost (within 1500 feet)

To activate the Driver Calling/Page feature:

1. Locate the Valet/Emergency Override button in your vehicle (Ask your installation shop)
  - With the ignition switch OFF, press and hold the Valet/Emergency override button for 2 seconds, then release.
  - The LCD transmitter will beep continually and the "DRIVER CALLING" icon will appear
  - Press and release button 5 to turn off transmitter page.

# Remote Start Features

## **Remote Starting**

To Remote Start the System:

1. Be sure the system is not in Valet Mode.
2. Press and hold Button 4 for three seconds.
  - The parking lights will flash 4 times and turn on.
  - The Siren will chirp 4 times.
  - The engine will start and run for the duration of its programmed Run Time.\*
  - The heater or air conditioner will turn on (if turned on prior to exiting the vehicle).

**\*If the engine fails to start on the first attempt, it will repeat the starting procedure 2 more times. If the vehicle fails to start after a total of 3 times the parking lights will flash 4 times and the doors will lock (if installed).**

Turn on the ignition and press the brake pedal to disengage the remote start feature and drive the vehicle.

## **Shut Down**

When the the Remote Start feature is active, any of the following actions will shutdown the engine:

1. Pressing Button 4.
  - After the engine shuts down the doors will lock (if installed).
2. Pressing the Brake Pedal.
3. Opening the Hood.
4. Remote Start Time-Out (completion of the timed run cycle).

## **Quick Stop**

The Quick Stop Feature allows you to exit the vehicle while the keeping the engine running for quick stops.

To leave the vehicle running:

1. With engine running push the Remote Start button on the Remote Transmitter.
  - The parking lights will turn On.
2. Remove the key from the ignition switch.
3. You may now exit the vehicle and lock the doors manually or using the Remote Transmitter

To resume control of the vehicle:

1. Unlock the doors manually or by pressing Disarm Button on the Remote Transmitter.
2. Turn on the ignition.
3. Press the Brake Pedal to disengaged the remote start.
  - The parking lights will turn Off.

## ***Automatic Start Mode***

The Automatic Start Mode allows the vehicle to automatically start the vehicle every one or two hours and run for the preset Run Time.

To turn on Auto Starting:

1. Turn Ignition switch Off and wait for 3 seconds.
2. Turn Ignition switch On and Off three times ending with Ignition in Off position
3. Press and release the Valet switch immediatly.

Parking lights will flash indicating that the Auto Start mode has been activated.

To turn off Auto Starting do one of the following:

- Turn ignition On.
- Arm and then Disarm the system
- Alarm or Panic the system

**\* Automatic Start Mode will stay active for 24 hours only.**



## Extended Features

### ***Ignition Door Locking***

For added safety, the Ignition Door Locking feature allows vehicles equipped with power door lock systems to automatically lock the doors when the ignition is turned on. If a door is open when the ignition is turned on, the Ignition Door Locking feature is disabled to protect against locking the keys inside the vehicle.

### ***Ignition Door Unlocking***

For added convenience, this feature automatically unlocks the doors after the ignition key is turned off. The Ignition Door Unlocking feature may also be completely disabled if desired.

### ***Dome Light Activation***

If the optional Dome Light Activation feature is installed, the dome light will turn on when the system is disarmed using the Remote Transmitter, and remain on for 30 seconds or until the ignition is turned on.

### ***Auxiliary Function Outputs***

The Astra 4000RS Series are equipped with 1 Auxiliary Channel Output allowing the convenience features of the system to be further expanded. This output can be programmed for pulsed, timed, or latched operation, and used to add a number of optional features such as: power trunk release, power window activation, power sunroof control, auxiliary lighting, audio/video system control, and more.

The **Pulsed** operation setting allows an output to activate as long as the button is held.

The **Timed** operation setting allows an output to activate when the transmitter button is pressed, and remain activated for 10 seconds or until the transmitter button is pressed again.

The **Latched** operation setting allows an output to activate when the transmitter button is pressed, and remain activated until the transmitter button is pressed again.

### ***Disarm with Auxiliary Function***

If Auxiliary 1 is installed to activate the vehicle's trunk release, the system can be programmed to automatically disarm the alarm when the trunk is opened using the transmitter. In this manner, the trunk can be accessed without first disarming the alarm.

### ***Remote Sensor Disable***

When parking the vehicle in areas susceptible to unwanted disturbance from animals or strong weather conditions that could cause the sensors to trigger, the sensor inputs can be temporarily bypassed using the Remote Transmitter, preventing possible false alarms.

To disable the sensor inputs :

1. Arm the system normally.
2. Within 5 seconds of Arming the system, press the Arm button again.
  - The siren will chirp 5 times and the parking lights will flash 5 times to indicate the sensors are disabled.
  - The sensors will remain disabled until the next arming cycle.

# System Installation

1. Thoroughly read and become familiar with the installation instructions before beginning the installation.
2. Review system contents:
  - Main Unit
  - Two 5-Button Remote Transmitters (4000RS)
  - One 5-Button & One LCD Two-Way Transmitter (4000RS-2W-1)
  - Siren
  - Shock Sensor
  - Harnesses
    - 6-Wire starter harness/Relay Module
    - 16-Pin main harness
    - 4-Pin shock sensor harness
    - 3-Pin door lock harness
    - LED harness
    - Override Switch harness
3. Verify vehicle is equipped with electronic fuel injection, and starts/idles normally before installation.
4. Determine if vehicle is equipped with a factory theft deterrent system and obtain proper bypass module if required.
5. Find a location to mount the hood pin switch that will not interfere with the opening of the hood, and is not in a position that can accumulate water. ***The hood pin is a safety device that must be installed to avoid remote starting during engine servicing.***
6. Verify with the owner, the mounting locations for all visible components, including the LED and Override switch.
7. Verify with the owner, the optional features of the Astra 4000RS Series and the features that must be programmed during installation.
8. Inspect and perform a function test of all vehicle systems before and after the installation.
9. Always use a Volt / Ohm meter for testing vehicle circuits. Never use a test light.
10. Always look before drilling any holes or mounting self-tapping screws. Be sure fuel lines and exterior wiring looms are clear as they are often close to the chassis and difficult to see.
11. Protect all wires running from the engine compartment to the interior of the vehicle by covering with electrical tape and split loom tubing. Be sure to use a grommet when routing wires through the firewall.
12. Properly fuse any additional accessories such as window modules, door lock actuators, etc., making sure to power them separate from the alarm module. This will ensure the functionality of the security system in the event of an accessory failure.

## ***Mounting the Control Unit***

The control unit must only be mounted in the interior of the vehicle. Do not mount the main unit in the engine compartment. Choose a mounting location that will not be easily accessible to a thief, and will not interfere with the operation of any vehicle components such as foot pedals, steering column, air vents, seat rails, etc.

Do not mount the control unit until after setting the internal jumpers and performing a complete operation check of the system. After installation is complete and performance verified, the control unit can be easily mounted using wire ties through the mounting tabs on the bottom of the unit.

## ***Mounting the Siren***

Choose a siren mounting location that is away from heat sources such as exhaust manifolds, and where it cannot be easily accessed from underneath the vehicle. Be sure to face the siren downward to prevent the collection of water in the siren's housing.

Always route all wires from the engine compartment into the interior of the vehicle through a proper grommet.

## ***Mounting the Shock Sensor***

Choose a suitable interior mounting location for the shock sensor that provides ample coverage of the vehicle. Keep the sensor away from the vehicle's ECM or other sources of electrical interference. Suggested mounting locations include air conditioning ducts, dashboard braces, or center console supports.

During proper operation, the shock sensor will detect impacts to the vehicle only and will not usually be triggered by slow rocking movements of the vehicle like those caused by wind.

# System Wiring

## 6-Wire Starter Harness

- Pin 1 **RED - A:** Main Power Input A (+). Connect to the battery or constant power wire at the ignition switch with a minimum 30 Amp supply. Remove the fuse until the installation is complete and all wiring is checked.
- Pin 2 **RED - B:** Main Power Input B (+). Connect to the battery or constant power wire at the ignition switch with a minimum 30 Amp supply. Note: if connecting at the ignition switch it is highly recommended to use separate power wires for each Red wire, each with a minimum 30A supply. Remove the fuse until the installation is completed and all wiring is checked.
- Pin 3 **BROWN:** Second Ignition Output (+). The Brown wire provides +12V for a second ignition wire. This wire may instead be programmed for use as a second accessory or second starter wire.
- Pin 4 **ORANGE:** Accessory Output (+). Connect to the accessory wire coming from the ignition switch that supplies power to the heater/air-conditioner. Some cars may have multiple accessory wires.
- Pin 5 **YELLOW:** Ignition Output (+). Connect to the main ignition wire that provides +12V when the ignition is on and while cranking the starter.
- Pin 6 **VIOLET:** Starter Output (+). Connect to the the vehicle's starter wire.

## 16-Pin Main Harness

- Pin 1 **BROWN/WHITE:** Horn Output (-) 500 mA. Connect to a relay to activate the vehicle's horn when the alarm is triggered. This wire may instead be programmed as an ignition 3 relay trigger.
- Pin 2 **BLACK/GRAY:** Tach Input. Connect to the vehicle's tach wire or a fuel injector wire if the tachless mode does not provide satisfactory operation.
- Pin 3 **BROWN:** Siren Output (+) 3A. The Brown wire must connect to the siren's red wire. The Black siren wire must be grounded.
- Pin 4 **GREEN:** Negative Door Input (-). Connect to the door switch circuit wire that shows ground when the door is open.
- Pin 5 **VIOLET:** Positive Door Input (+). Connect to the door switch circuit wire that shows +12V when the door is open. This type of door circuit is usually found on Ford vehicles.
- Pin 6 **YELLOW :** +12V Ignition Input. The Yellow wire must connect to a main ignition wire at the ignition harness. This wire must show +12V when the ignition is on and while cranking the starter. The voltage must not drop when the car is starting.
- Pin 7 **WHITE/BLACK:** Hood Pin Input (-). Connect the to the hood pin switch. The switch must provide a ground output when switch is opened.
- Pin 8 **BLACK:** Ground Input (-). The Black wire must connect to a solid chassis ground. Clean away any paint or dirt to insure the best possible ground.
- Pin 9 **BLACK/WHITE:** Dome Light Output (-) 500 mA. Connect to the wire that activates the vehicle's dome light, usually the door pin switch wire. (see Green and Violet door trigger wires). **Note: Must Use Relay.**
- Pin 10 **WHITE/VIOLET:** Factory Disarm Output (-) 500 mA. The Violet/white wire provides a ground output on disarming and before remote starting to disarm a factory security system. Connect to the wire that requires a ground pulse to disarm the factory security system.
- Pin 11 **BLUE/ORANGE:** Ground When Running Output (-) 500 mA. Connect to an optional factory security bypass module if required.

- Pin 12 **ORANGE**: Armed Output (-) 500 mA. The Orange wire provides a ground output while armed to activate a relay for starter defeat and anti-grind protection.
- Pin 13 **GRAY**: Auxiliary 1 Output (-) 500 mA. Connect to a relay for an optional feature such as trunk release, etc. This output may be programmed for momentary, timed, or latched operation.
- Pin 14 **GREEN/WHITE**: Brake Input (+). Connect to the wire that shows +12V when pressing the brake. The Green/white wire is a safety shutdown wire that must be connected.
- Pin 15 **WHITE**: Parking Light Output (+/-) relay. Connect the White wire to the circuit that shows +12V or ground only when the parking lights are on and set the internal parking light relay jumper to the proper polarity. For parking light circuits exceeding 10 amps, a relay is required. For vehicle's with independent left and right parking light circuits, diodes must be installed to keep the circuits separate. NOTE: Do not connect the WHITE wire to the vehicle's headlight circuit.
- Pin 16 **RED WIRE**: Module Power Input (+). Connect to a constant source of +12V.

## ***Plug-in Connectors***

**5-Pin White Connector**: Two Way Receiver Connector.

**4-Pin White Connector**: Dual stage shock sensor port.

**2-Pin Blue Connector**: Valet switch port. Mount program switch in an area that is easily accessible from the driver's position.

**2-Pin Red Connector**: LED port. Mount LED in an area where it may be easily seen from either side of the vehicle.

**3-Pin White Door Lock Connector**: Door lock port.

- BLUE WIRE - negative unlock output (-) 500mA.
- RED WIRE - (+) Not used
- GREEN WIRE - negative lock output (-) 500mA.

**5-PIN White Remote Start Relay Module**: Connect to Remote Start 6 Wire Relay Module

# Jumper Settings

## ***Jumper Selection***

Carefully separate the top and bottom halves of the main unit case. Once the cover is removed, the parking light polarity jumper will be visible next to the parking light relay. Set the jumper for the correct polarity output as described below, then reassemble the main unit case.

**Parking Light Output.** Selects the polarity (+/-) for the output of the on-board Parking Light relay.

Left Pin and Center Pin = negative

Right Pin and Center Pin = positive

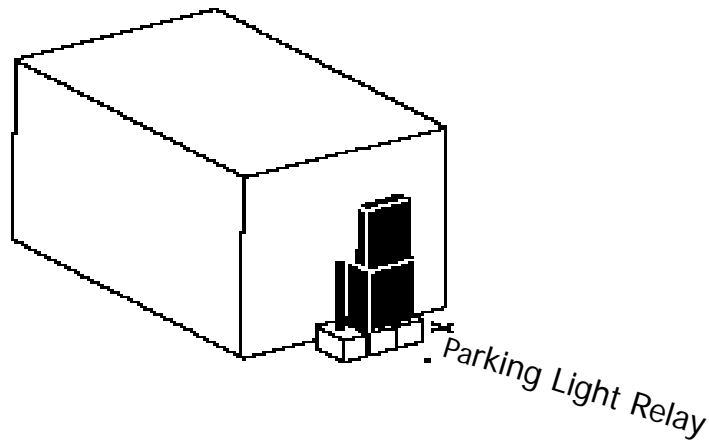

default setting shown

# System Programming

## **Entering System Programming**

The system programming is compatible with both the LCD transmitter or the standard AM transmitter.

To enter System Programming:

1. Turn on ignition.
2. Within 5 seconds, press the valet switch 5 times.
  - The siren will provide three chirps, indicating that you have entered Programming.
3. Press the valet switch the number times equal to the System Parameter you want to change.
  - The siren will chirp each time the valet switch is pressed.
4. Within 5 seconds, press the transmitter button corresponding to the desired operating mode for that System Parameter.
  - The siren will chirp to indicate the setting.

1 chirp	=	Button 1
2 chirps	=	Button 2
3 chirps	=	Button 3
5. When you are finished, turn off the ignition to save the changes.

## **Default Reset**

Following this procedure will set all System Programming Parameters to factory default settings.

1. Enter System Programming.
2. Press Transmitter Button 3.
  - The siren will chirp 6 times indicating that the reset signal was received.
  - All System Programming parameters are now set to factory default settings.
  - The Valet Mode is off.
3. Turn off ignition.

## **Programmable System Options**

The following is a description of the programming options of the system. Some of the program branches control more than one option, and may require accessing a particular branch number twice in order to program all desired features.

1. **Arm Mode.** Selects between Manual and Passive Arming.
2. **Auto Rearming Mode.** When selected, the system will automatically re-arm and lock 30 seconds after it is disarmed regardless if a door is open or closed.
3. **Arming Chirps.** Selects between normal and silent operation.
4. **Warn-Away Pager Report.** When Enabled, Warn-Away report will be sent to the pager. If Disabled no Warn-Away report will be sent to the pager.
5. **Extended Parking Lights.** When Enabled, upon Disarming Parking lights will turn On for 30 seconds or until the Dome light turns Off.
6. **Ignition Door Locking / Override Code Set.** This dual program branch selects Ignition Door

Branch	Feature	Button 1 (default)	Button 2	Button 3
1.	Arm Mode	Manual Arming	Passive Arming	
2.	Auto Rearming Mode	Disabled	Enabled	
3.	Arming Chirps	Siren Chirps On	Silent	Siren & Horn Chirps On
4.	Warn-Away Pager Report	Enabled	Disabled	
5.	Extended Parking Lights	On	Off	
6.	Ignition Door Locking	On	Off	Set Override Code
7.	Ignition Door Unlocking	On	Off	
8.	Door Unlock Pulse	Single	Double	
9.	Door Lock Pulse Length	1 second	3 seconds	0.1 seconds
10.	Passive Door Locking	Disabled	Enabled	
11.	Ignore Open Door Report	Report	Ignore	
12.	Aux 1 Mode	Pulsed	Timed	Latched
13.	Disarm with Aux 1	Disabled	Enabled	
14.	Starter Confirmation Chirps	Disabled	Enabled	
15.	Start in Valet Mode	Disabled	Enabled	
16.	Lock after Start	On	Off	
17.	Lock after Shutdown	On	Off	
18.	Engine Run Time	15 minutes	25 minutes	
19.	Automatic Start Mode	2 hours	1 hour	
20.	Tachless Sense Crank Time	Normal	Extended	Super Extended
21.	Remote Start Program	RPM Mode/RPM Learn	Gas Engine	Diesel Engine
22.	Ignition 2 Output Program	Ignition 2 Output	Accessory 2 Output	Starter 2 Output
23.	Ignition Door Lock Mode	RPM dependant	Instant	

Locking, and programs the optional Emergency Override Code.

Ignition Door Locking. Selects whether or not the system will automatically lock the doors 10 seconds after the ignition key is turned on.

Override Code Set. Changes the Emergency Override Code for a higher level of security.

7. **Ignition Door Unlocking.** Selects whether or not the system automatically unlocks the doors when the ignition is turned off.
8. **Door Unlock Pulse.** Selects between one pulse or two pulse operation for the door unlock output. Many new import vehicles' factory door locking systems require two pulses on the proper wire to unlock the doors. These systems can be interfaced directly without the use of relays or any additional circuitry by programming the system for double unlock pulse.
9. **Door Lock Pulse Length.** Selects between a 1-second, 3-second or 0.1 second output for door locking and unlocking. Program to 3 seconds for vehicles equipped with vacuum door locking systems. 0.1 seconds for vehicles that roll windows up or down when lock/unlock output is at 1 second.
10. **Passive Door Locking.** Selects whether or not the system will automatically lock the doors during Passive Arming.
11. **Ignore Open Door Report.** Bypasses the open zone warning chirps for vehicles equipped with a residual dome light circuit that remains on for a period of time after closing the door.
12. **Auxiliary 1 Mode.** Selects from momentary, 10 second timed, or latched operation for Auxiliary 1.



Momentary operation provides an output for as long as the transmitter button is pressed.

Timed operation provides an output that turns on for 10 seconds each time the transmitter button is pressed. If the button is pressed again during the 30 seconds, the output will turn off.

Latched operation provides an output that turns on when the transmitter button is pressed and remains on until the transmitter button is pressed again.

13. **Disarm with Auxiliary 1.** When selected, activating the Auxiliary 1 output (usually used to open the trunk) will disarm the alarm.
14. **Starter Confirmation Chirps.** When Enabled, siren will chirp to confirm Starter Active state.
15. **Start in Valet Mode.** Selects whether or not the vehicle can remote start while in the valet mode.
16. **Lock After Start.** When selected, the doors will automatically lock after remote starting.
17. **Lock After Shutdown.** When selected, the doors will automatically lock after remote shutdown.
18. **Engine Run Time.** Selects between 15 or 25 minutes for the remote start run cycle.
19. **Automatic Start Mode.** Selects between every two hours or every hours for the automatic engine starting feature.
20. **Tachless Sense Crank Time.** Selecting engine crank time automatically selects the tachless mode and one of three crank times.

If the normal engine crank time is too short increase the time by selecting one of the two additional extended crank time options.

Normal - 0.8Sec.

Extended - 1.0Sec.

Super Extended - 1.4Sec.

Tachless Mode. Determines the engine status using an advanced software routine, without requiring connection to the vehicle's tachometer. Tachless operation may not be compatible with some vehicles or in severe temperatures, in which case the tach wire must be connected.

21. **Remote Start Program.** This dual program branch sets the engine mode for Gas or Diesel, and learns the vehicle's RPM threshold. Learning the RPM threshold automatically selects the RPM monitor mode. For installation into a diesel equipped vehicle, first set the engine type to diesel before learning RPM.

Tach Monitor Mode. Monitors the vehicle's tach wire (or a fuel injection wire) in real-time to determine engine status and adjust starter crank time automatically. If programmed for Tach Monitor, the vehicle's tach signal will have to be learned before initial operation (see below).

RPM Learn. Start the engine, enter Branch 21 and press Button 1 to learn the vehicle's tach signal. The siren will chirp and the LED will flash once to confirm learning of the tach signal and entering Tach Monitor Mode. The siren will chirp four times and the LED will flash four times if the tach signal was not learned, engine sense mode will not be changed.

Gas Engine. Sets the engine type for Gasoline.

Diesel Engine. Sets the engine type for Diesel and monitors the glow plug input to make sure the glow plugs are warm before cranking the starter. If the glow plug wire is not connected, the built-in timer waits 15 seconds before automatically cranking the starter.

22. **Ignition 2 Relay Program.** Selects one of three operating modes for the Ignition 2 relay output: Ignition 2, Accessory 2, or Starter 2.
23. **Ignition Door Lock Mode.** Selects Lock when engine RPM exceeds twice the idle, and Lock 3 seconds after ignition is turned On.

# Relay Diagrams

Positive Dome Light Activation

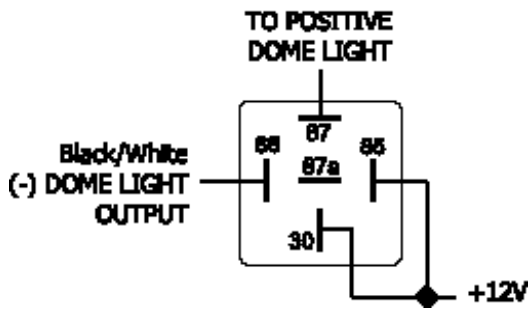

Negative Dome Light Activation

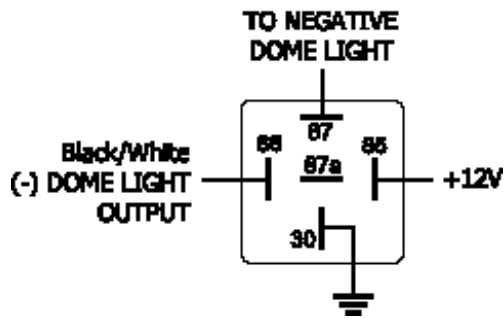

Positive Horn Honk

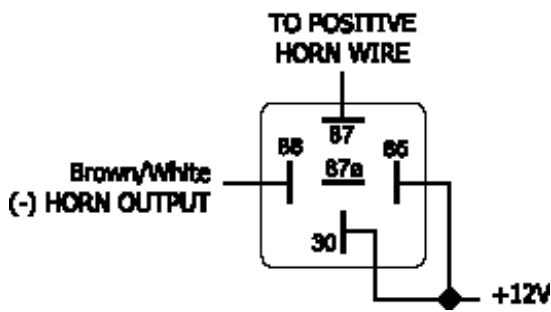

Negative Horn Honk

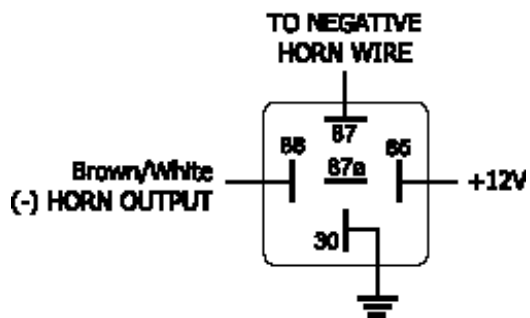

Negative Glow Plug

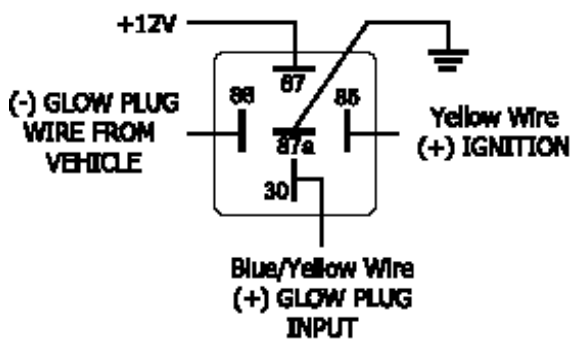

Starter Defeat/Anti-Grind

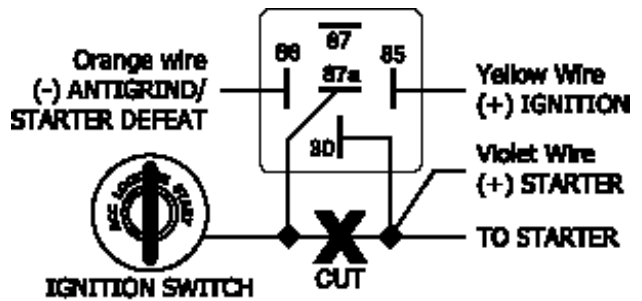

# Door Lock Diagrams

Follow the diagrams below for connecting basic door lock systems. For Two Stage door lock systems (separately unlocks driver and passenger doors) see following pages.

### Negative Trigger

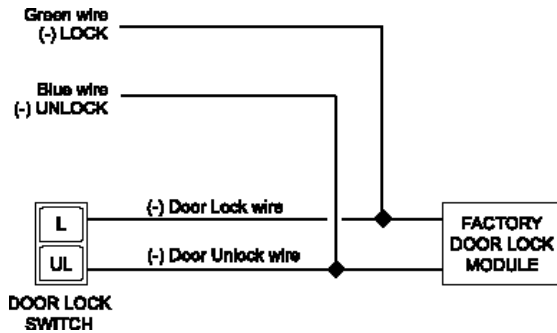

### Positive Trigger

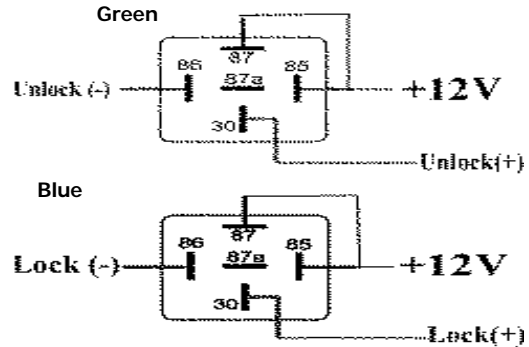

### Reverse Polarity

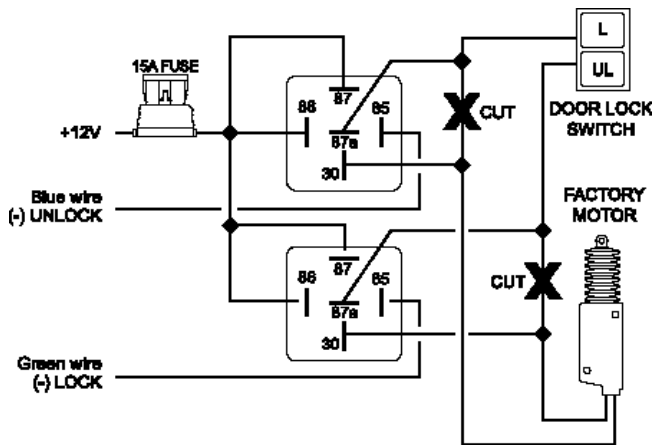

### Vacuum

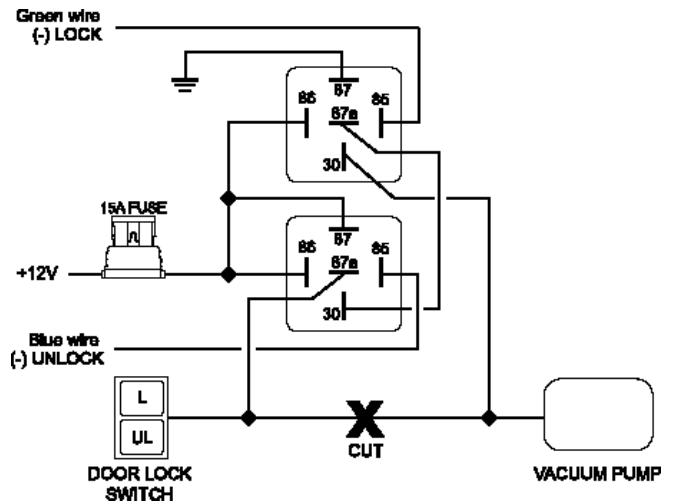

### Adding Actuators

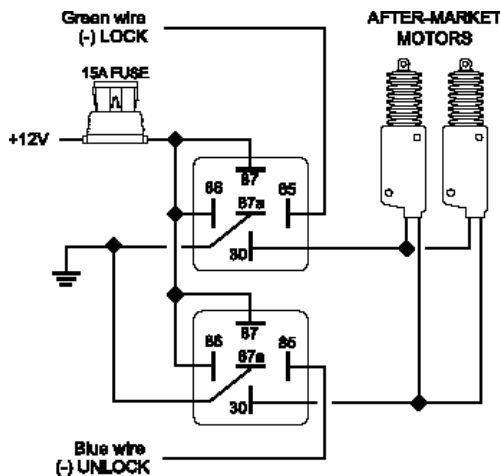

# Two Stage Door Lock Diagrams

The Astra 4000RS Series can be wired for the Passenger Unlock output feature, allowing Two Stage Door Lock operation. When connected as shown below, disarming the system will unlock only the driver's door. Pressing the Aux 1 button will unlock all doors.

## Two Stage Negative Trigger

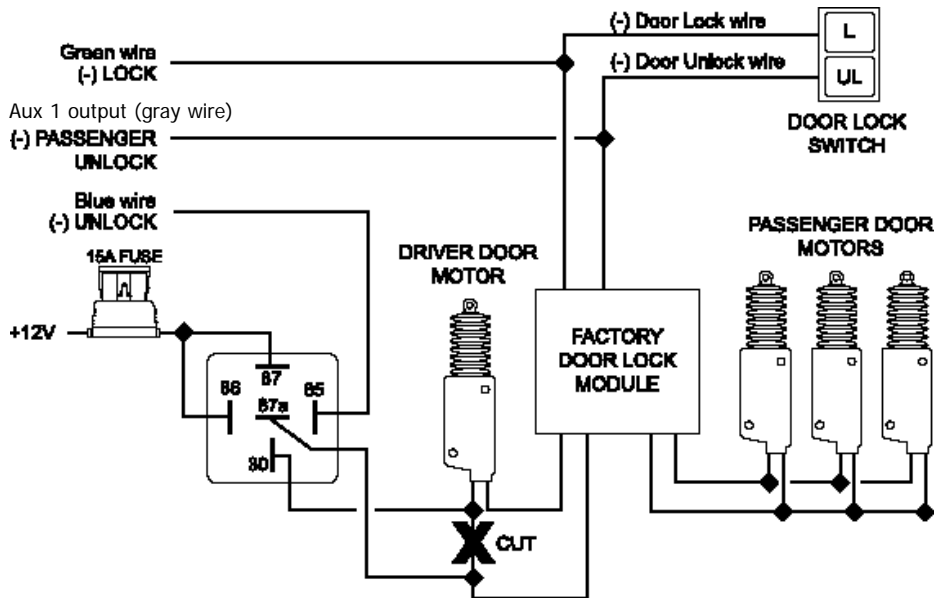

## Two Stage Positive Trigger(using inverter)

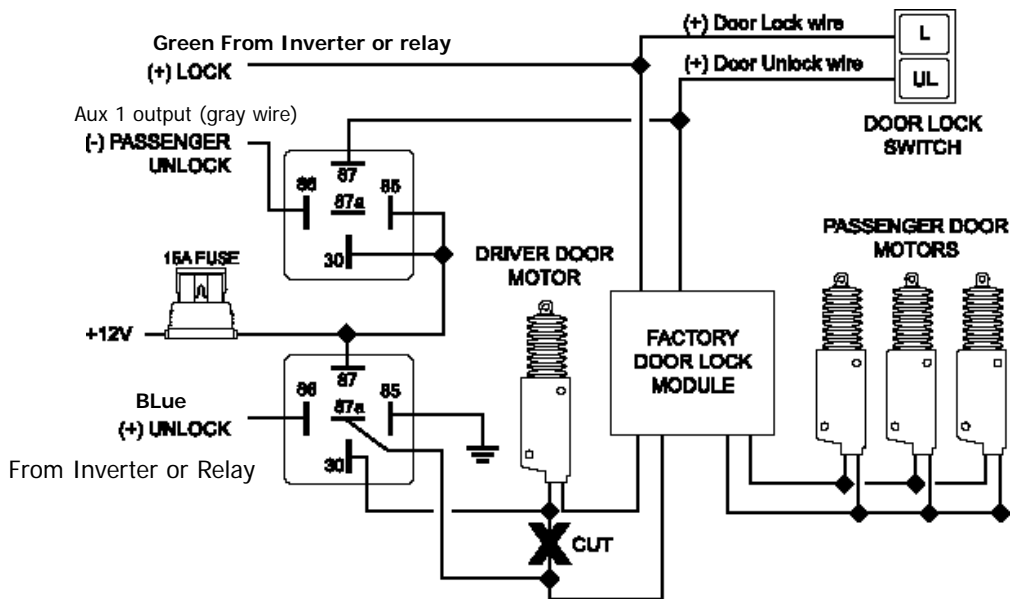

# Two Stage Door Lock Diagrams cont'd

## Two Stage Reverse Polarity

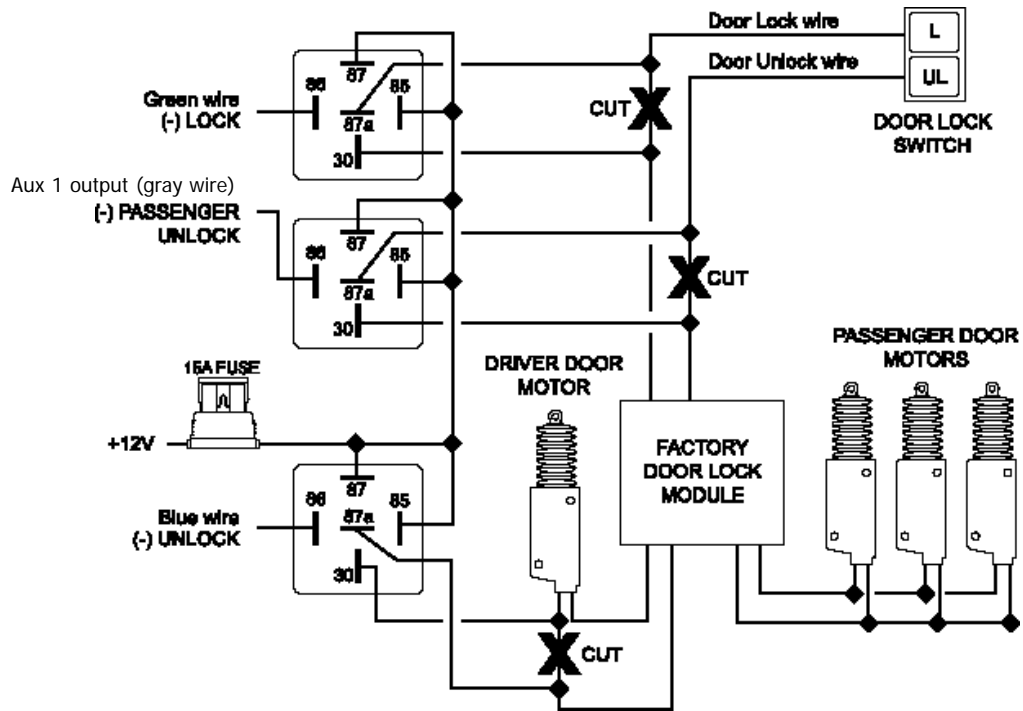

## Two Stage Adding Actuators

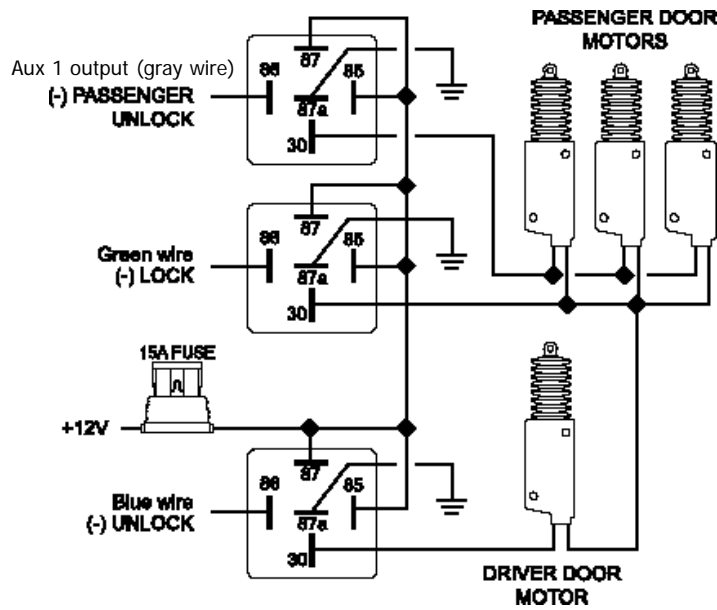

## Technical Information

### FCC ID: OARRXAM2000

This device complies with Part 15 of FCC Rules.

Operation is subject to the following two conditions:

- 1) This device may not cause harmful interference.
- 2) This device must accept any interference received, including interference that may cause undesired operation

## Starter Diagnostics

Starter doesn't start and parking lights flash:

- 3 Times - **Engine RPM not detected (check tach wire and/or perform tach learn procedure)**  
**Hood Trigger is active (hood is open, wire is shorted to ground or pin switch is defective)**
- 4 Times - **Brake Trigger is active ( Brake switch input is shorted to ground or incorrect)**
- 5 Times - **Unit is in Valet (service) mode, and start is disabled.**

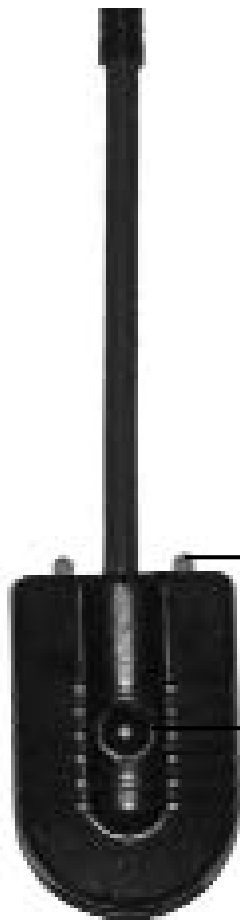

RS Series

LED LIGHT

CALL/Valet/Emergency Override Switch

Valet/Override Switch



RS-2W Series

LED LIGHT

# Wiring Diagram

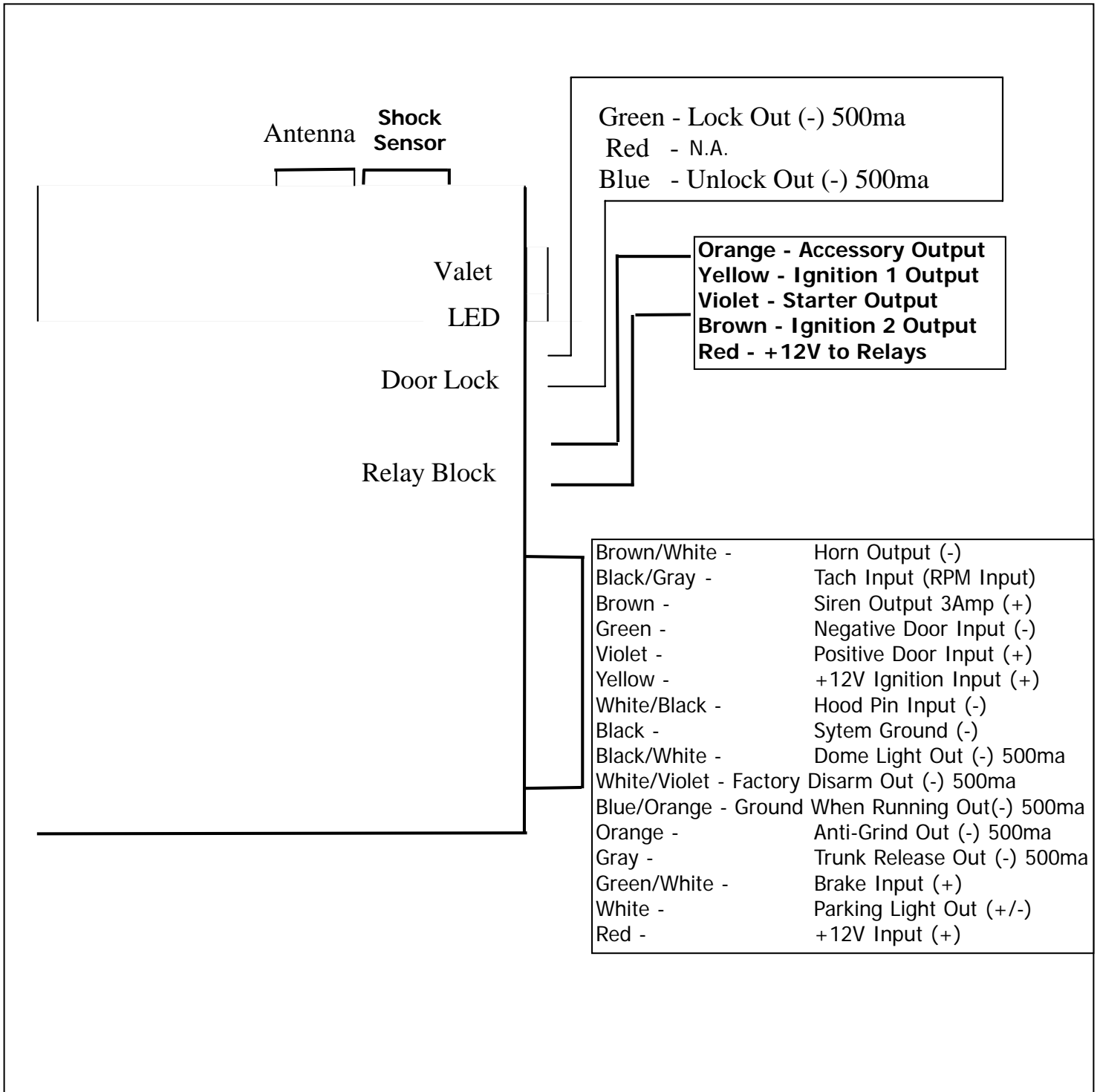

## ScyTek Electronics

11627 Cantara Street  
North Hollywood, CA 91605  
www.scytek.net